

HADC-2005PI / HABC-2005PI

1080P AHD Vandal IR Fixed Lens Camera

Featuring the advanced Analog High Definition (AHD) video technology, HADC-2005PI / HABC-2005PI is a HD analog camera which provides 1080P (1920 x 1080) sharp, high definition images. The AHD technology ensures real-time and non compressed signal transmission via coaxial cable, which significantly reduces installation cost and provides much sharper images without video quality loss.

Market Opportunities

The HADC-2005PI / HABC-2005PI cameras are cost effective surveillance solutions suitable for both indoor and outdoor applications, including schools, colleges, hotels, hospitals, commercial sites, retail stores, warehouses, banks and so on. Featuring 3.6mm built-in lens, 1080P resolution, TDN function and IR night vision. It is also ideal for easy and cost-effective upgrade of existing analog system to high definition surveillance.



HADC-2005PI



HABC-2005PI

KEY FEATURES

- 1080P real time high resolution
- CMOS progressive scan
- True day/night capability
- Minimum illumination: 0 Lux (IR ON)
- TDN (IR-cut), AWB, AGC, Defog
- 3.6mm Lens
- IR distance: upto 20m, depending on scene reflectance (HADC-2005PI) and upto 25m, depending on scene reflectance (HABC-2005PI)
- Power: 12VDC
- Vandal resistant
- Dual output AHD & CVBS

HADC-2005PI/ HABC-2005PI

1080P AHD Vandal IR Dome Cameras

SPECIFICATIONS

Part Code	HADC-2005PI	HABC-2005PI
System		
Video Standard	PAL/NTSC	
Scanning System	Progressive	
Image Sensor	1/2.7" 2MP CMOS Sensor	
Resolution	1080P	
Number of Pixels	1920 (H) x 1080 (V)	
Minimum Illumination	0.01Lux BW, 0Lux IR	
Video Output	AHD BNC, CVBS terminal	
Video Frame Rate	25/30 fps (PAL/NTSC)	
Sync System	Internal	
Automatic Electronic Shutter	1/25s ~ 1/50,000s(PAL), 1/30s ~ 1/60,000s(NTSC)	
Lens Type	3.6mm	
IR LEDS	18 LEDS	20 LEDS
IR Illumination Distance	Upto 20m, depending on scene reflectance	Upto 25m, depending on scene reflectance
SNR	≥50 db	
Day/Night	Auto with ICR	
Automatic Gain Control	Auto	
White Balance	Auto	
Digital Noise Reduction	Auto (3DNR)	
WDR	DWDR (ON/OFF)	
OSD	Yes	
Electrical		
Input Voltage	DC12V ± 10%, 500mA	
Power Consumption	6W ± 10%	
Mechanical		
Dimensions	∅ 93 x 74(H) mm	157(W) x 70(H) x 66(D)mm
Weight	400g	650g
Construction	Housing: Vandal resistant, Color: Semi-white	
Connectors	Video output: AHD BNC connector; CVBS terminal, Power input: 2.1 mm plug	
Environmental		
Operating Temperature	-10°C to 50°C	
Relative Humidity	10% to 95%, non-condensing	
IP Rating	IP66	IP66
Regulatory		
Certification	CE	
System Compatibility		
Compatible DVR	AHD DVR	

Note: Honeywell reserves the right, without notification, to make changes in product design and/or specifications.

DIMENSIONS

1080P AHD Vandal IR Dome Cameras

HADC-2005PI

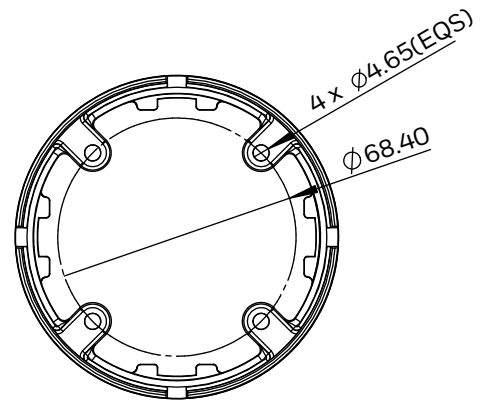
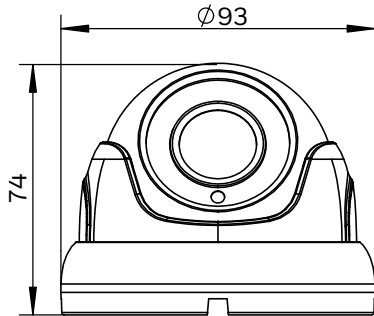

HABC-2005PI

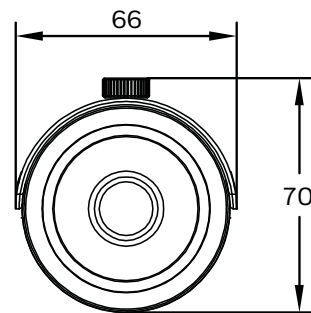
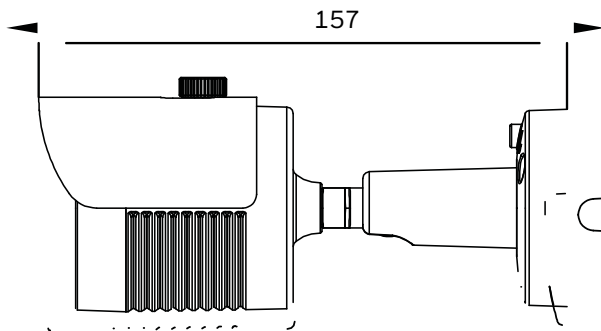

ORDERING INFORMATION

HADC-2005PI	1/2.7" CMOS Sensor, 1080P AHD, TDN, DNR, DWDR, 18 LED, 3.6mm, IR Vandal Dome Camera, 12 VDC with OSD, PAL
HABC-2005PI	1/2.7" CMOS Sensor, 1080P AHD, TDN, DNR, DWDR, 20 LED, 3.6mm, IR Vandal Bullet Camera, 12 VDC with OSD, PAL

For more information, please contact:

Email: buildings.asean@honeywell.com

Malaysia (ASEAN Headquarters)

Honeywell International Sdn. Bhd.
Level 25, UOA Corp Tower B, Avenue 10
The Vertical, Bangsar South City,
59200, Kuala Lumpur, Malaysia

Indonesia

PT. Honeywell Indonesia
Menara Prima, 23rd Floor
Jl. DR. Ide Anak Agung Gde Agung Blok 6.2
Kawasan Mega Kuningan, Jakarta 12950,
Indonesia

Philippines

Honeywell International Philippines, Inc.
25th & 26th Floor, The Curve BGC 32nd corner
3rd Avenue, Bonifacio Global City, Taguig City
Philippines 1634

Singapore

Honeywell Pte. Ltd.
17 Changi Business Park Central 1
Honeywell Building, Singapore 486073

Thailand

Honeywell Systems (Thailand) Ltd.
252/121 25th Floor
Muang Thai-Phatra office Tower II
Ratchadapisek Road, Huay Khwang
Bangkok 10320, Thailand

Vietnam

Honeywell Vietnam Co.,Ltd.
Suite 1406-1408, Level 14, Pacific Place Building,
83B Ly Thuong Kiet, Hoan Kiem District, Hanoi
Vietnam

Honeywell Vietnam Co.,Ltd.
Suite 11, 5th Floor, Crescent Plaza,
105 Ton Dat Tien Street, Tan Phu Ward, District 7,
HCMC Vietnam

Myanmar

Honeywell Myanmar
No. 35, U Kyaw Hla Street, 7th Mile,
Mayangone Township, Yangon 11061
Myanmar

Honeywell